

One-Step Equations

Purpose

Students will write, solve, and check one-step linear equations and inequalities in one variable.

Materials

For the teacher: chalk, chalkboard, set of 5 long rectangle and 25 small square algebra tiles or paper strips and squares

For each student: copy of Black Line Master (BLM) *Solving Equations Using Algebra Tiles*

For each pair of students: copy of BLM *Balance*, set of 5 long rectangle and 25 small square algebra tiles or paper strips and squares

Activity

A. Introduction

1. Tell students you are thinking of a number. Say: "If 13 were added to this number the result would be 29. What is the number?" [16] Ask students for their answers and the method they used to determine the answer.
2. Say: "If 25 were subtracted from this number the result would be 14. What is the number?" [39] Ask students for their answers and the method they used to determine the answer.
3. Write these two examples on the chalkboard in linear equation form. Tell students that the equal sign acts as a balance between the left and right sides of the equation. Explain that both sides of the equation get equal treatment. Explain that inverse operations are used to solve the equation. Solve the two problems on the board using inverse operations, keeping in mind the balance model. Tell students to check the solution by substituting it back into the original equation.
4. Ask students what would happen if we replaced the "=" with "<" or ">." Indicate to students that the same *balancing* method would be used for solving the inequality. Give the students this example: "solving $x + 9 < 52$ for x tells us that x must be less than 43." Have students test this solution by substituting two numbers less than 43 for x , then 2 numbers greater than 43. Stress that the numbers greater than 43 make the expression false. Explain to students that they should always check inequalities in this manner.

(continued)



INCORPORATING TECHNOLOGY

Have students visit the AAA Math Web site (www.aaamath.com/equ725-equation3.html#section3) to play one of the equation-solving games.



EXTENDING THE ACTIVITY

Have students devise a method to solve equations involving subtraction using algebra tiles and the balance model. One possibility would be to create different colored small squares with one color to represent numbers that are being subtracted and the other color to represent numbers being added.

Standards Links
6.1.1, 6.2.1

Activity (continued)

- Tell students that the solution for an equation should be expressed as an equation and the solution for an inequality should be expressed as an inequality.

B. Partner Activity

- Break the class into groups of two. Give each group a set of algebra tiles (or paper strips and squares) and a copy of the BLM *Balance*.
- Explain to students that each small square represents one unit and each long rectangle represents a value of “ x ” in an equation. Ask students to model some algebraic expressions using the tiles. (e.g, $x + 2$ as one long rectangle and two small squares, $2 \times x$ as two long rectangles)
- Ask students to use the BLM *Balance* to model the equation $x + 3 = 12$. (The left side holds one long rectangle and 3 small squares and the right side of the balance holds 12 small squares.) Have students determine the value of x and check their solution by substituting it back into the original equation.
- Discuss student approaches and results. (One possible approach is to take 3 small squares away from each side of the balance. Now, only x remains on the left and 9 small squares on the right, giving a solution of $x = 9$.)
- Repeat steps 5 through 7 using the equation $3x = 15$. (In order to solve this equation the student must identify the need to form three groups of 5 from the 15 individual squares. Removing two rectangles from one side of the balance requires the removal of two groups of 5 from the other side of the balance, giving a solution of $x = 5$.) Have students check by substituting the solution into the original equation.
- Distribute a copy of the BLM *Solving Equations Using Algebraic Tiles* to each student and have them work with their partner to complete the activity.

Classroom Assessment

Basic Concepts and Processes

While students are working on the partner activity, ask the following questions:

 What operation would you use to solve the equation $x + 2 = 12$?

 If $x + 2 = 12$, what does x equal?

 What operation would you use to solve the equation $5x = 25$?

 If $5x = 25$, what does x equal?

 How would you check your solution in both cases?

SOLVING EQUATIONS USING ALGEBRA TILES

For each equation, prepare a model using algebra tiles and a balance. Solve the equation and write the operation used to obtain the solution. Express your solution as an equation.

Example:

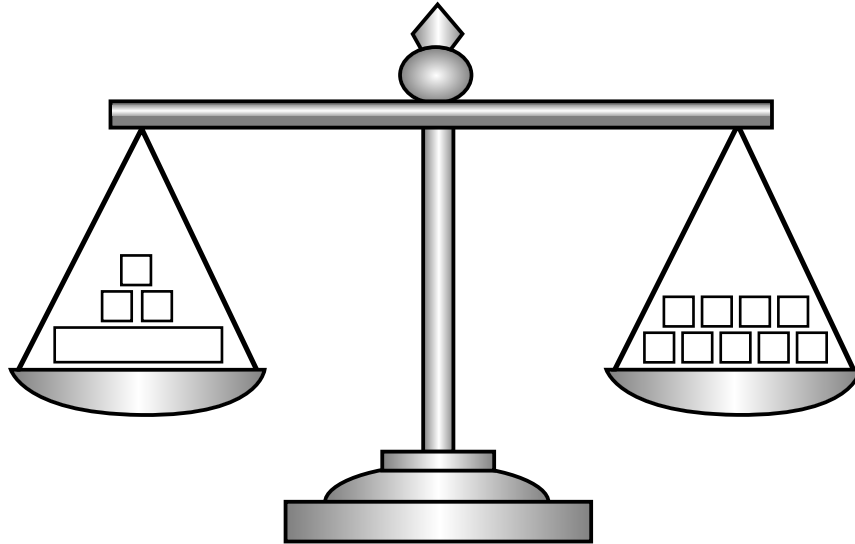

Equation: $x + 3 = 9$

Operation: subtract 3 units from each side

Solution: $x=6$

Equation	Operation	Solution
1. $x + 5 = 16$		
2. $x + 7 = 11$		
3. $x + 2 = 12$		
4. $x + 9 = 13$		
5. $2x = 12$		
6. $3x = 12$		
7. $4x = 20$		

SOLVING EQUATIONS USING ALGEBRA TILES

Teacher Directions

Distribute copies of the BLMs *Solving Equations Using Algebra Tiles* and *Balance* to students. Have students complete the chart showing the operation used for solving the equation along with the solution expressed as an equation. Direct students to use algebra tiles (or paper strips and squares) and a copy of the BLM *Balance* to complete the exercises.

Remind students to check each solution by substituting it into the original equation.

Answer Key

Equation	Operation	Solution
1. $x + 5 = 16$	subtract 5	$x = 11$
2. $x + 7 = 11$	subtract 7	$x = 4$
3. $x + 2 = 12$	subtract 2	$x = 10$
4. $x + 9 = 13$	subtract 9	$x = 4$
5. $2x = 12$	divide by 2	$x = 6$
6. $3x = 12$	divide by 3	$x = 4$
7. $4x = 20$	divide by 4	$x = 5$

BALANCE

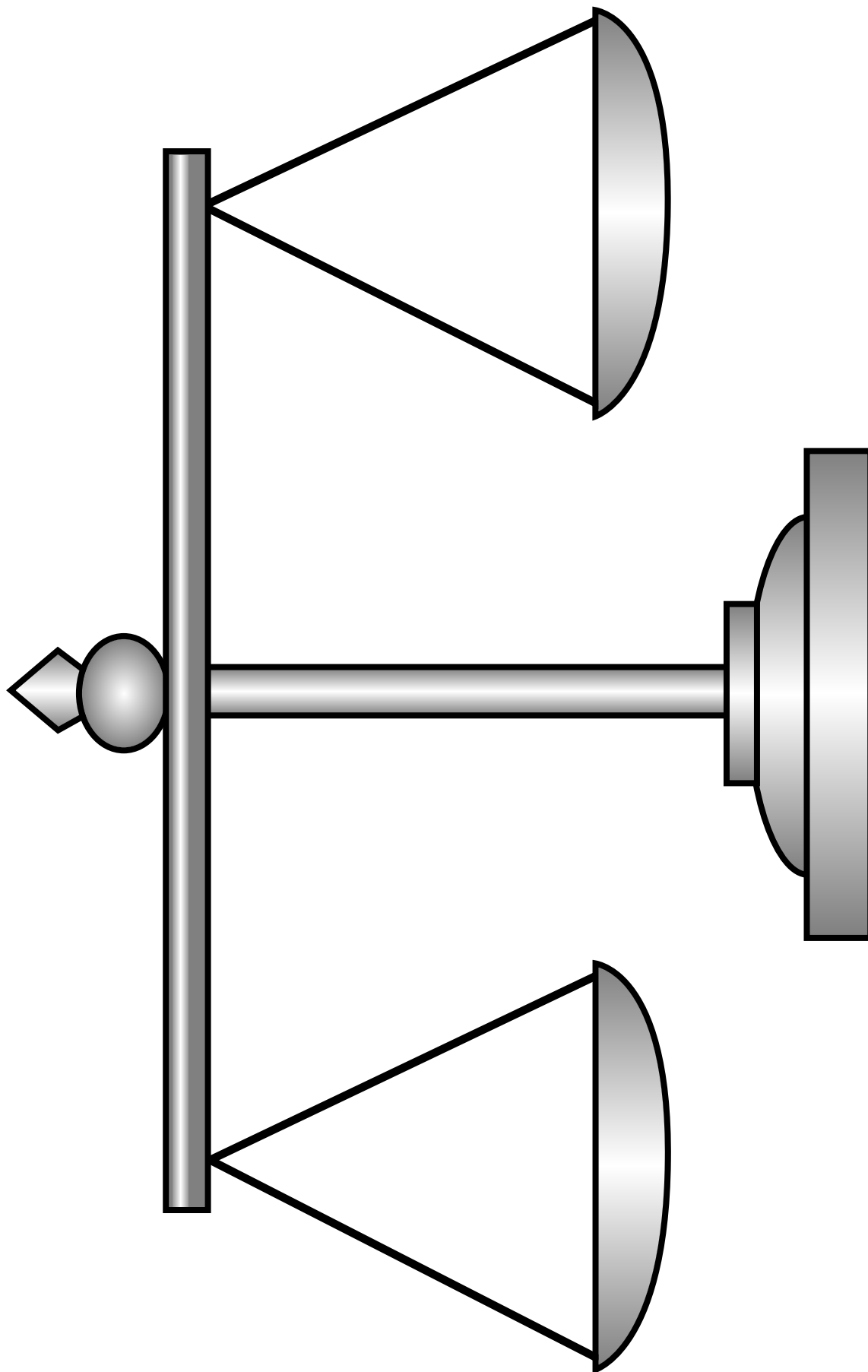

BALANCE

Teacher Directions

Have students use BLM *Balance* to help solve the equations on BLM *Solving Equations Using Algebra Tiles*.

Answer Key

Not applicable.